



MachXO3 sysI/O User Guide

Technical Notes

FPGA-TN-02056-2.0

June 2025

Disclaimers

Lattice makes no warranty, representation, or guarantee regarding the accuracy of information contained in this document or the suitability of its products for any particular purpose. All information herein is provided AS IS, with all faults, and all associated risk is the responsibility entirely of the Buyer. The information provided herein is for informational purposes only and may contain technical inaccuracies or omissions, and may be otherwise rendered inaccurate for many reasons, and Lattice assumes no obligation to update or otherwise correct or revise this information. Products sold by Lattice have been subject to limited testing and it is the Buyer's responsibility to independently determine the suitability of any products and to test and verify the same. LATTICE PRODUCTS AND SERVICES ARE NOT DESIGNED, MANUFACTURED, OR TESTED FOR USE IN LIFE OR SAFETY CRITICAL SYSTEMS, HAZARDOUS ENVIRONMENTS, OR ANY OTHER ENVIRONMENTS REQUIRING FAIL-SAFE PERFORMANCE, INCLUDING ANY APPLICATION IN WHICH THE FAILURE OF THE PRODUCT OR SERVICE COULD LEAD TO DEATH, PERSONAL INJURY, SEVERE PROPERTY DAMAGE OR ENVIRONMENTAL HARM (COLLECTIVELY, "HIGH-RISK USES"). FURTHER, BUYER MUST TAKE PRUDENT STEPS TO PROTECT AGAINST PRODUCT AND SERVICE FAILURES, INCLUDING PROVIDING APPROPRIATE REDUNDANCIES, FAIL-SAFE FEATURES, AND/OR SHUT-DOWN MECHANISMS. LATTICE EXPRESSLY DISCLAIMS ANY EXPRESS OR IMPLIED WARRANTY OF FITNESS OF THE PRODUCTS OR SERVICES FOR HIGH-RISK USES. The information provided in this document is proprietary to Lattice Semiconductor, and Lattice reserves the right to make any changes to the information in this document or to any products at any time without notice.

Contents

Contents.....	3
Abbreviations in This Document.....	7
1. Introduction.....	8
2. sysI/O Buffer Overview.....	8
3. Supported sysI/O Standards.....	9
4. sysI/O Banking Scheme.....	10
5. sysI/O Standards Supported by I/O Banks.....	12
6. Power Supply.....	13
7. V _{CCIO} Requirement for I/O Standards.....	13
8. Input Reference Voltage.....	15
9. sysI/O Buffer Configuration.....	15
9.1. LVCMOS Buffer Configurations.....	15
9.1.1. Bus Maintenance Circuit.....	15
9.1.2. Programmable Drive Strength.....	15
9.1.3. Input Hysteresis.....	15
9.1.4. Programmable Slew Rate.....	15
9.1.5. Tristate and Open Drain Control.....	16
9.2. Differential Buffer Configurations.....	16
9.2.1. Differential Receivers.....	16
9.2.2. On-Chip Input Termination.....	16
9.2.3. Emulated Differential Outputs.....	16
9.3. True Differential Output and Output Drive.....	16
10. Software sysI/O Attributes.....	17
10.1. HDL Attributes.....	17
10.1.1. IO_TYPE.....	17
10.1.2. DRIVE.....	18
10.1.3. DIFFDRIVE.....	18
10.1.4. PULLMODE.....	18
10.1.5. CLAMP.....	18
10.1.6. HYSTERESIS.....	18
10.1.7. VREF.....	19
10.1.8. OPENDRAIN.....	19
10.1.9. SLEWRATE.....	19
10.1.10. DIFFRESISTOR.....	19
10.1.11. DIN/DOUT.....	19
10.1.12. LOC.....	19
10.1.13. Bank VCCIO.....	20
10.2. sysI/O Primitives.....	20
10.2.1. Tri-State All (TSALL).....	20
10.2.2. Fixed Data Delay (DELAYE).....	20
10.2.3. Dynamic Data Delay (DELAYD).....	21
11. Design Consideration and Usage.....	22
11.1. sysI/O Buffer Features Common to All MachXO3L/LF Devices.....	22
11.2. sysI/O Buffer Rules.....	22
Appendix A – sysI/O HDL Attributes.....	23
A.1. Attributes in VHDL Language.....	23
A.2. Attributes in Verilog Language.....	25
Appendix B – sysI/O HDL Attributes Using Spreadsheet View.....	27
B.1. Attributes in Verilog Language.....	27
Appendix C – sysI/O Attributes Using Preference File (ASCII File).....	29
Appendix D. Issue: GPIO Input Prevents Powering Down the FPGA.....	30
D.1. GPIO Input Current Leakage Pathway.....	30

D.2. Workarounds.....	30
References	32
Technical Support Assistance	33
Revision History	34

Figures

Figure 2.1. PIC Block Diagram	8
Figure 4.1. MachXO3L/LF-640 and MachXO3L/LF-1300 I/O Banking Arrangement	10
Figure 4.2. MachXO3L/LF-1300, MachXO3L/LF-2100, MachXO3L/LF-4300, MachXO3L/LF-6900, and MachXO3L/LF-9400 I/O Banking Arrangement	11
Figure 10.1. TSALL Primitive	20
Figure 10.2. DELAYE Primitive and Associated Attributes	20
Figure 10.3. DELAYE Primitive	21
Figure B.1. Port Assignment Tab of Spreadsheet View	27
Figure B.2. Cell Attribute Tab	28
Figure D.1. Potential Current Path for Powered Down FPGA with Driven Input	30

Tables

Table 3.1. Supported Input Standards	9
Table 3.2. Supported Output Standards	9
Table 5.1. Supported Output Standards	12
Table 5.2. Supported Output Standards	12
Table 7.1. Mixed Voltage Support for LVCMOS and LVTTTL I/O Types ⁸	13
Table 7.2. Mixed Voltage Support for Differential Input Standards	14
Table 10.1. Supported I/O Types	17
Table 10.2. Output Drive Capability for Ratioed sysI/O Standards	18
Table 10.3. DELAYE Primitive and Associated Attributes	20
Table 11.1. Miscellaneous I/O Features on Each Device Edge	22
Table A.1. VHDL Attribute Syntax	23
Table A.2. VHDL Attribute Syntax	25

Abbreviations in This Document

A list of abbreviations used in this document.

Abbreviation	Definition
ASCII	American Standard Code for Information Interchange
BLVDS	Bidirectional Low Voltage Differential Signaling
DDR	Double Data Rate
DRC	Design Rule Check
FPGA	Field-Programmable Gate Array
HDL	Hardware Description Language
IBIS	Input/Output Buffer Information Specification
LPF	Lattice Preference File
LVC MOS	Low-Voltage Complementary Metal Oxide Semiconductor
LVDS	Low-Voltage Differential Signaling
LVPECL	Low Voltage Positive Emitter Coupled Logic
LVTTTL	Low Voltage Transistor-Transistor Logic
MIPI	Mobile Industry Processor Interface
MLVDS	Multipoint Low-Voltage Differential Signaling
PCI	Peripheral Component Interconnect
PIO	Parallel Input/Output
PIC	Programmable Input/Output Cell
PLB	Programmable Logic Block
PLD	Programmable Logic Device
VHDL	VHSIC Hardware Description Language
VIH	Voltage Input High
VIL	Voltage Input Low

1. Introduction

The MachXO3™ programmable logic device (PLD) family sysI/O™ buffers are designed to meet the needs of flexible I/O standards in today’s fast-paced design world. The supported I/O standards range from single-ended I/O standards to differential I/O standards so that you can easily interface your designs to standard buses, memory devices, video applications and emerging standards. This technical note provides a description of the supported I/O standards and the banking scheme for the MachXO3L/LF PLD family. The sysI/O architecture and the software usage are also discussed to provide a better understanding of the I/O functionality and placement rules.

2. sysI/O Buffer Overview

The basic building block of the MachXO3L/LF sysI/O is the Programmable I/O Cell (PIC) block. There are three types of PIC blocks in the MachXO3L/LF device architecture. These include the basic PIC block, the receiving PIC block with gearing, and the transmitting PIC block with gearing. The PIC blocks with gearing are used for video and high-speed applications. The PIC blocks with gearing have a built-in control module for word alignment. The details of the gearing PIC block can be found in [Implementing High-Speed Interfaces with MachXO3 Devices \(FPGA-TN-02057\)](#).

A common feature of all three types of PIC blocks is that each PIC block consists of four programmable I/O (PIO). Each PIO includes a sysI/O buffer and an I/O logic block. A simplified sysI/O block diagram is shown in [Figure 2.1](#). The I/O logic block consists of an input block, an output block, and a tristate block. These blocks have registers, input delay cells, and the necessary control logic to support various operational modes. The sysI/O buffer determines the compliance to the supported I/O standards. It also supports features like hysteresis to meet common design needs. The I/O logic block and the sysI/O buffer are designed with a minimal use of die area, providing easy bus interfacing and pin out efficiency.

Two adjacent PIOs can form a pair of complementary output drivers. In addition, PIOA and PIOB of the PIC block form the primary pair of the buffer, while PIOC and PIOD form the alternate pair of the buffer. The primary pairs have additional capability that is not available on the alternate pair. The sysI/O buffers of the PIC block are equivalent when implemented as the single-ended I/O standards.

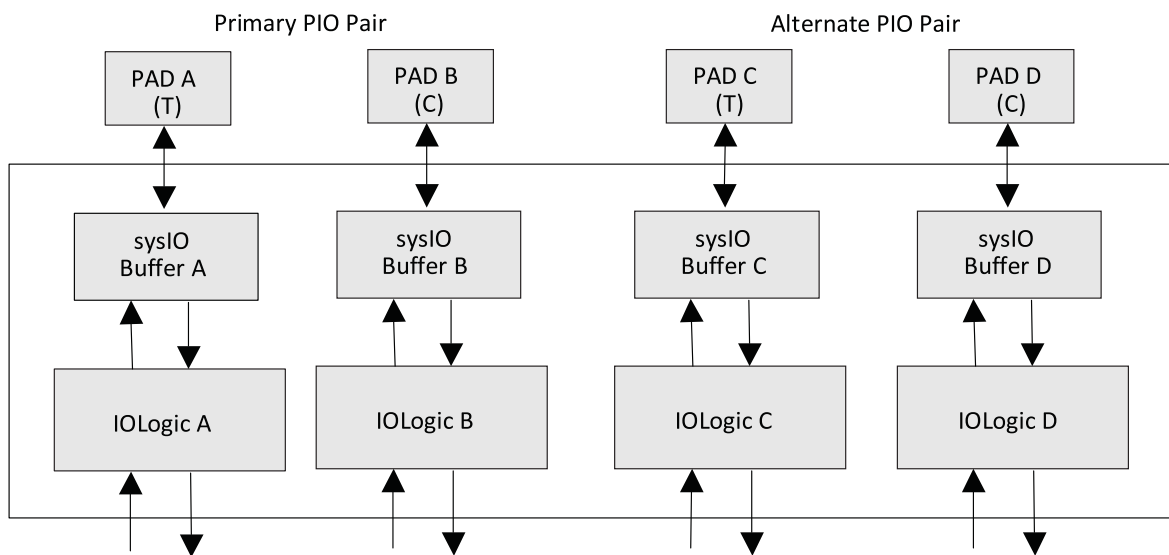

Figure 2.1. PIC Block Diagram

3. Supported sysI/O Standards

The Lattice MachXO3L/LF sysI/O buffer supports both single-ended and differential standards. The internally ratioed standards support individually configurable drive strength and bus maintenance circuits, such as weak pull-up, weak pull-down, or bus keeper.

All banks of the MachXO3L/LF devices support true differential inputs, and emulated differential outputs using external resistors and the complementary LVCMOS outputs. The true-LVDS differential outputs and LVDS input termination are supported in specific banks, as described in the [sysI/O Banking Scheme](#) section of this document.

Table 3.1. Supported Input Standards

Input Standard	V _{REF} (Nominal)	V _{CCIO} ¹ (Nominal)
Single-Ended Interfaces		
LVTTTL33	—	—
LVC MOS33	—	—
LVC MOS25	—	—
LVC MOS18	—	—
LVC MOS15	—	—
LVC MOS12	—	—
Differential Interfaces		
LVDS25	—	—
LVPECL33	—	—
MLVDS25	—	—
BLVDS25	—	—
LVTTTL33D	—	—
MIPI ²	—	—

Notes:

1. If not specified, refer to mixed voltage support in the [VCCIO Requirement for I/O Standards](#) section.
2. This interface can be emulated with external resistors.

Table 3.2. Supported Output Standards

Output Standard	Drive (mA)	V _{CCIO} (Nominal)
Single-Ended Interfaces		
LVTTTL33	4, 8, 12, 16	3.3
LVC MOS33	4, 8, 12, 16	3.3
LVC MOS25	4, 8, 12	2.5
LVC MOS18	4, 8, 12	1.8
LVC MOS15	4, 8	1.5
LVC MOS12	2, 6	1.2
Differential Interfaces		
LVDS25	3.5	2.5, 3.3
LVDS25E	8	2.5
LVPECL33E	16	3.3
MLVDS25E	16	2.5
BLVDS25E	16	2.5
LVTTTL33 Differential	4, 8, 12, 16	3.3
LVC MOS33 Differential	4, 8, 12, 16	3.3
LVC MOS25 Differential	4, 8, 12	2.5
MIPI ¹	2	2.5

Note:

1. This interface can be emulated with external resistors. Refer to [MIPI D-PHY Interface IP \(FPGA-RD-02040\)](#) for information on support for MIPI input and output.

4. sysI/O Banking Scheme

The MachXO3L/LF family has a non-homogeneous I/O banking structure. MachXO3L/LF-640 and MachXO3L/LF-1300 have four I/O banks each with one I/O bank per side. MachXO3L/LF-1300, MachXO3L/LF-2100, MachXO3L/LF-4300, MachXO3L/LF-6900, and MachXO3L/LF 9400 devices have six I/O banks each, with one I/O bank on each of the top, bottom, and right sides, and three banks on the left side.

The MachXO3L/LF devices support true LVDS differential outputs through the primary pairs on the top bank, Bank 0. These devices also support 100 Ω differential input termination on every I/O pair on the bottom I/O bank.

Each of the I/O pins on all MachXO3L/LF PLDs has a clamp feature which can be disabled or enabled. This clamp is similar to the PCI clamp but it is not PCI compliant. The arrangements of the I/O banks are shown in [Figure 4.1](#) and [Figure 4.2](#). When the CLAMP DIODE is ON, careful design considerations must be followed. See [Appendix D](#) for more information.

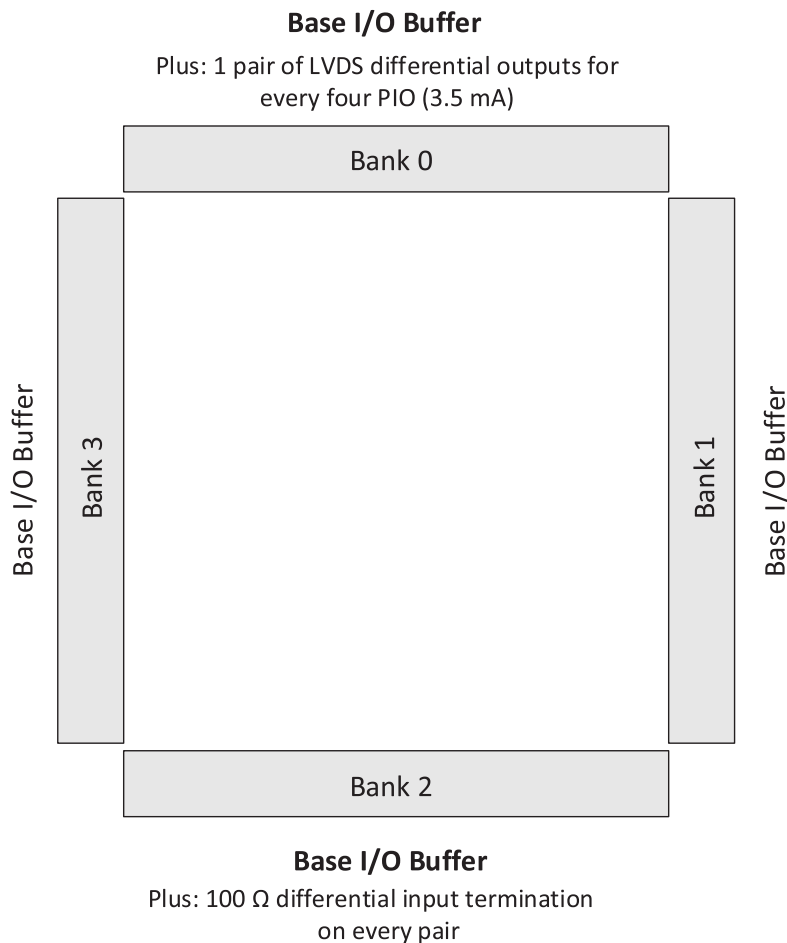

Figure 4.1. MachXO3L/LF-640 and MachXO3L/LF-1300 I/O Banking Arrangement

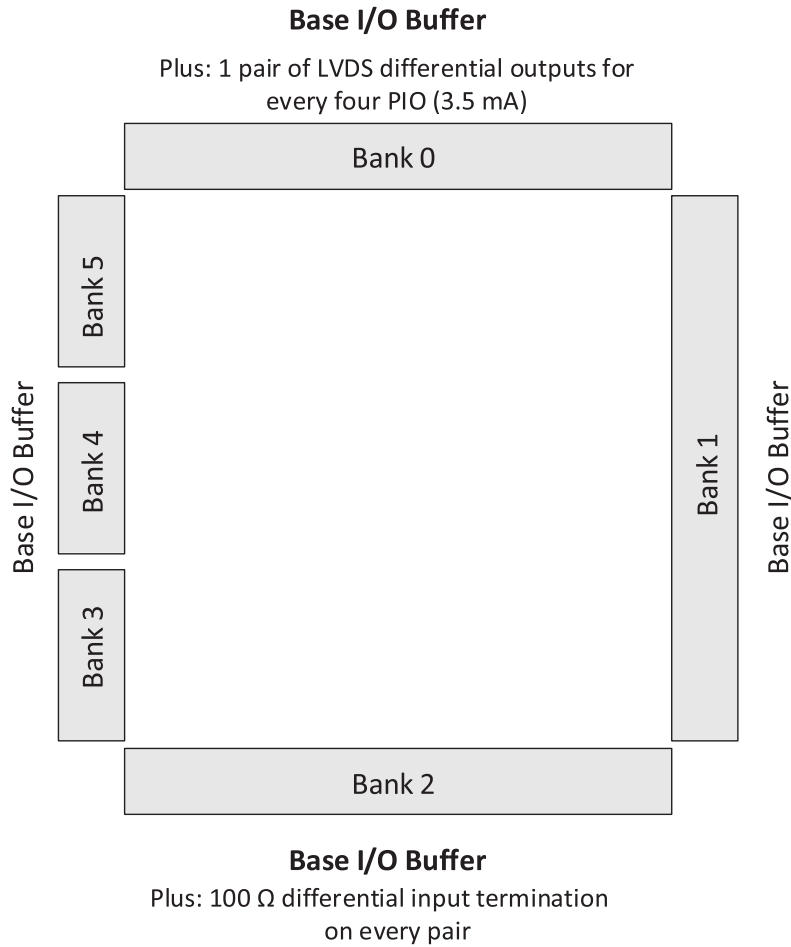

Figure 4.2. MachXO3L/LF-1300, MachXO3L/LF-2100, MachXO3L/LF-4300, MachXO3L/LF-6900, and MachXO3L/LF-9400 I/O Banking Arrangement

5. sysI/O Standards Supported by I/O Banks

All banks can support multiple I/O standards under the V_{CCIO} rules discussed above. [Table 5.1](#) and [Table 5.2](#) summarize the I/O standards supported on various sides of the MachXO3L/LF device.

Table 5.1. Supported Output Standards

Standard	Top	Bottom	Left	Right
LVTTL33	Yes	Yes	Yes	Yes
LVC MOS33	Yes	Yes	Yes	Yes
LVC MOS25	Yes	Yes	Yes	Yes
LVC MOS18	Yes	Yes	Yes	Yes
LVC MOS15	Yes	Yes	Yes	Yes
LVC MOS12	Yes	Yes	Yes	Yes

Table 5.2. Supported Output Standards

Standard	Top	Bottom	Left	Right
LVDS output	Yes ¹	—	—	—
LVPECL33E ²	Yes	Yes	Yes	Yes
MLVDS25E ²	Yes	Yes	Yes	Yes
BLVDS25E ²	Yes	Yes	Yes	Yes
LVDS25E ²	Yes	Yes	Yes	Yes
LVTTL33D output	Yes	Yes	Yes	Yes
LVC MOS33D output	Yes	Yes	Yes	Yes
LVC MOS25D output	Yes	Yes	Yes	Yes
LVDS input	Yes	Yes	Yes	Yes
LVPECL33 input	Yes	Yes	Yes	Yes
MLVDS25 input	Yes	Yes	Yes	Yes
BLVDS25 input	Yes	Yes	Yes	Yes
LVTTL33D input	Yes	Yes	Yes	Yes
LVC MOS33D input	Yes	Yes	Yes	Yes
LVC MOS25D input	Yes	Yes	Yes	Yes
MIPI	Yes	Yes	Yes	Yes

Notes:

1. True LVDS output is supported at the top bank.
2. Emulated output standards are denoted with a trailing E in the name of the standard.

6. Power Supply

The MachXO3L/LF device family has a simplified power supply scheme for sysI/O buffers. The core power V_{CC} and the bank power V_{CCIO} are the two main power supplies. A MachXO3L/LF device can be powered and operated with a single power supply by connecting V_{CC} and V_{CCIO} to nominal voltages of 1.2 V. The JTAG programming pins are powered by V_{CCIO} in bank 0 where the JTAG pins reside. All the user sysI/O have a weak pull-down after power-up is complete and before the device configuration is done.

7. V_{CCIO} Requirement for I/O Standards

Each I/O bank of a MachXO3L/LF device has a separate V_{CCIO} supply pin that can be connected to 1.2 V, 1.5 V, 1.8 V, 2.5 V, or 3.3 V. This voltage is used to power the output I/O standard and source the drive strength for the output. In addition to this, V_{CCIO} also powers the ratioed input buffers, such as LVTTTL and LVCMOS. This ensures that the threshold of the input buffers is tracking the V_{CCIO} voltage level.

Input buffer set up to be a 1.2 V ratioed input can be used on bank set to any V_{CCIO} . This is possible because the MachXO3L/LF sysI/O buffer has two ratioed input buffers connected to V_{CCIO} and V_{CC} in parallel.

Table 7.1. Mixed Voltage Support for LVCMOS and LVTTTL I/O Types⁸

V_{CCIO}	Inputs						Outputs					
	1.0 V	1.2 V	1.5 V	1.8 V	2.5 V	3.3 V	1.0 V	1.2 V	1.5 V	1.8 V	2.5 V	3.3 V
1.2 V	—	Yes	Yes ⁶	—	—	—	—	Yes	—	—	—	—
1.5 V	—	Yes ¹	Yes	Yes ⁶	Yes ⁶	Yes ⁶	—	—	Yes	—	—	—
1.8 V	—	Yes ¹	Yes ⁵	Yes	Yes ⁶	Yes ⁶	—	—	—	Yes	—	—
2.5 V	Yes ^{1,9}	Yes ^{1,10}	Yes ^{2,5,7}	Yes ^{3,5,7}	Yes	Yes ⁶	Yes ¹¹	Yes ¹¹	—	—	Yes	—
3.3 V	Yes ^{1,9}	Yes ^{1,10}	Yes ^{2,5,7}	Yes ^{3,5,7}	Yes ^{4,5,7}	Yes	Yes ¹¹	Yes ¹¹	—	—	—	Yes

Notes:

- Leakage occurs if bus hold or weak pull-up is turned on.
- This input standard can be supported using the ratioed input buffer in under-drive conditions or using the I/O types LVCMOS15R25 or LVCMOS15R33 with the referenced input buffer.
- This input standard can be supported using the ratioed input buffer in under-drive conditions or using the I/O type LVCMOS18R25 or LVCMOS18R33 with the referenced input buffer.
- This input standard can be supported using the ratioed input buffer in under-drive conditions or using the I/O type LVCMOS25R33 with the referenced input buffer.
- Under-drive condition when using the ratioed input buffer and the input standard voltage is below V_{CCIO} .
 - Under-drive causes higher DC current when the I/O is at logic high. It is recommended to use Power Calculator to estimate the power consumption under such condition.
 - Hysteresis is not supported. In the Lattice Diamond™ software, HYSTERESIS must be set to NA.
 - CLAMP is not supported. In the Lattice Diamond software, CLAMP must be set to OFF.
 - I/O termination is not supported. In the Lattice Diamond software, PULLMODE must be set to NONE.
- Over-drive condition when using the ratioed input buffer and the input standard voltage is above V_{CCIO} :
 - Hysteresis is not supported. In the Lattice Diamond software, HYSTERESIS must be set to NA.
 - CLAMP is not supported. In the Lattice Diamond software, CLAMP must be set to OFF.
 - I/O termination is not supported. In the Lattice Diamond software, PULLMODE must be set to NONE.
- Ratioed input buffer in under-drive conditions is preferred over referenced input buffer due to lower power requirement for the ratioed input buffer.
- When using the ratioed input buffers in under-drive or over-drive conditions, the HYSTERESIS setting shall be NA, the CLAMP setting shall be OFF, and the UP and KEEPER PULLMODE settings are not supported.
- This input standard can be supported using the I/O types LVCMOS10R25 or LVCMOS10R33 with the referenced input buffer. However, LVCMOS10R25 and LVCMOS10R33 I/O types are available only for -6 speed grade.
- This input standard can be supported using the ratioed input buffer in under-drive conditions or using the I/O types LVCMOS12R25 or LVCMOS12R33 with the referenced input buffer.
- This output standard is supported as a Bidirectional open-drain buffer only. I/O termination is not supported. In the Lattice Diamond software, OPENDRAIN must be set to ON, PULLMODE must be set to NONE, and CLAMP must be set to OFF.

For differential input standards, certain mixed voltage support is allowed in the architecture, as shown in [Table 7.2](#).

Table 7.2. Mixed Voltage Support for Differential Input Standards

V _{CCIO}	Differential Inputs		
	LVDS LVPECL33 MLVDS25 BLVDS25	LVTTTL33D LVCMOS33D	LVC MOS25D
1.2 V	—	—	—
1.5 V	—	—	—
1.8 V	—	—	—
2.5 V	Yes	—	Yes
3.3 V	Yes	Yes	Yes

8. Input Reference Voltage

To support Mixed Voltage I/O using the referenced input buffer, each I/O bank supports one reference voltage, VREF. Any I/O in the bank can be configured as the input reference voltage pin. This pin is a regular I/O if it is not used as reference voltage input.

9. sysI/O Buffer Configuration

Each sysI/O buffer pair is made of two PIO buffers. PIO A and B pads form the primary pair, and PIO C and D pads form the alternate pair. Pads A and C of the pair are considered the true pad, while pads B and D are considered the comp pad. The true pad is associated with the positive side of the differential signal, while the comp pad is associated with the negative side of the differential signal.

All the PIOs support bus maintenance circuitry to allow a weak pull-up, a weak pull-down, or a weak bus keeper. The LVDS sysI/O buffer pairs have additional LVDS output drivers in the primary PIO and are available on the top side of the device. The bottom sysI/O buffer pairs have additional 100 Ω termination resistors between the true and comp pads.

9.1. LVCMOS Buffer Configurations

The LVCMOS buffers can be configured in a variety of modes to support common circuit design needs.

9.1.1. Bus Maintenance Circuit

Each pad has a weak pull-up, weak pull-down, and weak bus-keeper capability. These are selected with ON and OFF programmability. The pull-up and pull-down settings offer a fixed characteristic, which is useful in creating wired logic, such as wired ORs. The bus-keeper option latches the signal in the last driven state, holding it at a valid level with minimal power dissipation. Input leakage can be minimized by turning off the bus maintenance circuitry. However, it is important to ensure that inputs are driven to a known state to avoid unnecessary power dissipation in the input buffer. The bus maintenance circuit is available for single-ended ratioed I/O standards.

9.1.2. Programmable Drive Strength

All single-ended drivers have programmable drive strength. This option can be set for each I/O independently. The drive strengths available for each I/O standard can be found in [Table 10.2](#). The MachXO3L/LF programmable drive architecture is guaranteed with minimum drive strength for each drive setting. The V/I curves in the data sheet provide details of output driving capability versus the output load. This information, together with the current per bank and the package thermal limit current, should be taken into consideration when selecting the drive strength.

9.1.3. Input Hysteresis

Voltage Input High (VIH) is the trip point for a low-to-high transition and Voltage Input Low (VIL) is the trip point for a high-to-low transition, hysteresis voltage is the difference between VIH and VIL. Hysteresis is used to prevent several quick successive changes, for example, when the input signal contains some noise. The noise could mean that you cross the trip point more than just once, which causes a glitch in the system.

All ratioed input receivers, except LVCMOS12, support input hysteresis. The input hysteresis for the LVCMOS33, LVCMOS25, LVCMOS18, and LVCMOS15 have two settings for flexibility. The ratioed input receivers have no input hysteresis when they are operated in under-drive or over-drive input conditions, as shown in [Table 10.1](#).

9.1.4. Programmable Slew Rate

The single-ended output buffer for each device I/O pin has programmable output slew rate control that can be configured for either low noise performance, SLEWRATE=SLOW, or high speed performance, SLEWRATE=FAST. Each I/O pin has an individual slew rate control. This slew rate control affects both the rising and the falling edges. The rise and fall ramp rates for each I/O standard can be found in the in the device Input/Output Buffer Information Specification (IBIS) file for a given I/O configuration.

9.1.5. Tristate and Open Drain Control

Each single-ended output driver has a separate tristate control in addition to the global tristate control for the device. The single-ended output drivers also support open drain operation on each I/O independently. The open drain output is typically pulled up externally and only the sink current specification is maintained.

9.2. Differential Buffer Configurations

The sysI/O buffer pair supports differential input standards. The top and bottom edges support some additional functions over those supported by the base sysI/O buffer pairs.

9.2.1. Differential Receivers

All the sysI/O buffer pairs support differential input on all edges of the device. When a sysI/O buffer pair is configured as differential receiver, the input hysteresis and the bus maintenance capabilities is disabled for the buffer.

9.2.2. On-Chip Input Termination

The MachXO3L/LF device supports on-chip 100 Ω nominal input differential termination on the bottom edge. The termination is available on all input PIO pairs of the bottom edge and is programmable.

9.2.3. Emulated Differential Outputs

All sysI/O buffer pairs support complementary outputs as described above. This feature can be used to drive complementary LVCMOS signals. It can also be used together with off-chip resistor networks for emulating the differential output standards such as LVPECL, MLVDS, MIPI, and BLVDS differential standards. When a sysI/O buffer pair is configured as differential transmitter, the bus maintenance and open drain capabilities is disabled. All single-ended sysI/O buffers pairs in the MachXO3L/LF family can support emulated differential output standards.

9.3. True Differential Output and Output Drive

MachXO3L/LF devices support true differential output drivers on the top edge of these devices. These true differential outputs are only available on the primary PIO pairs. The output driver has a fixed common mode of 1.2 V and a programmable drive current of 3.5 mA. The bank V_{CCIO} for true differential output can be 2.5 V or 3.3 V.

10. Software sysI/O Attributes

The sysI/O attributes or primitives must be used in the Lattice development software to control the functions and capabilities of the sysI/O buffers. sysI/O attributes or primitives can be specified in the HDL source code, in the Lattice Diamond Spreadsheet View user interface, or in the ASCII preference .lpf file directly. Appendices A, B, and C list examples of using such attributes in different environments. This section describes each of these attributes in detail.

10.1. HDL Attributes

All the attributes discussed in this section, except two, can be used in the HDL source code to direct the sysI/O buffer functionality.

10.1.1. IO_TYPE

This attribute is used to set the sysI/O standard for an I/O. The V_{CCIO} required to set these I/O standards are embedded in the attribute names. The BANK V_{CCIO} attribute is used to specify the allowed V_{CCIO} combinations for each I/O type.

Table 10.1 shows the valid I/O types for the MachXO3L/LF family.

Table 10.1. Supported I/O Types

sysI/O Signaling Standard	IO_TYPE
LVDS 2.5 V	LVDS25
Emulated LVDS 2.5 V ¹	LVDS25E
Bus LVDS 2.5 V	BLVDS25
Emulated Bus LVDS 2.5 V ¹	BLVDS25E
MLVDS 2.5 V	MLVDS25
Emulated MLVDS 2.5 V ¹	MLVDS25E
LVPECL 3.3 V	LVPECL33
Emulated LVPECL 3.3 V ¹	LVPECL33E
LVTTTL 3.3 V	LVTTTL33
LVTTTL 3.3 V differential ²	LVTTTL33D
LVC MOS 3.3 V	LVC MOS33
LVC MOS 3.3 V differential ²	LVC MOS33D
LVC MOS 2.5 V (default)	LVC MOS25
LVC MOS 2.5 V differential ²	LVC MOS25D
LVC MOS 2.5 V in 3.3 V V_{CCIO} bank ³	LVC MOS25R33
LVC MOS 1.8 V	LVC MOS18
LVC MOS 1.8 V in 3.3 V V_{CCIO} bank ³	LVC MOS18R33
LVC MOS 1.8 V in 2.5 V V_{CCIO} bank ³	LVC MOS18R25
LVC MOS 1.5 V	LVC MOS15
LVC MOS 1.5 V in 3.3 V V_{CCIO} bank ³	LVC MOS15R33
LVTTTL 3.3 V	LVTTTL33
LVC MOS 1.5 V in 2.5 V V_{CCIO} bank ³	LVC MOS15R25
LVC MOS 1.2 V	LVC MOS12
LVC MOS 1.2 V in 3.3 V V_{CCIO} bank ⁴	LVC MOS12R33
LVC MOS 1.2 V in 2.5 V V_{CCIO} bank ⁴	LVC MOS12R25
LVC MOS 1.0 V in 3.3 V V_{CCIO} bank ⁴	LVC MOS10R33
LVC MOS 1.0 V in 2.5 V V_{CCIO} bank ⁴	LVC MOS10R25
MIPI	MIPI

Notes:

1. These differential output standards are emulated by using a complementary LVC MOS driver pair together with an external resistor pack.
2. These differential standards are implemented by using a complementary LVC MOS driver pair.

3. These are input only and require VREF to be set to certain value to allow the specified I/O types to be used.
4. These are input or bidirectional only and require VREF to be set to certain value to allow the specified I/O types to be used.

10.1.2. DRIVE

The DRIVE strength attribute is available for the output and bidirectional I/O standards. The default drive value depends on the I/O standard used. [Table 10.2](#) shows the supported drive strength for single-ended I/O types under designated I/O standards.

Table 10.2. Output Drive Capability for Ratioed sysI/O Standards

Drive Strength (mA)	I/O Type					
	LVC MOS12	LVC MOS15	LVC MOS18	LVC MOS25	LVC MOS33	LV TTL33
2	YES	—	—	—	—	—
4	—	YES	YES	YES	YES	YES
6	YES	—	—	—	—	—
8	—	YES	YES	YES	YES	YES
12	—	—	YES	YES	YES	YES
16	—	—	—	—	YES	YES

10.1.3. DIFFDRIVE

The DIFFDRIVE strength attribute is available for the true LVDS output standard. All true LVDS differential drivers on the top edge is set to 3.5 mA setting. This is not programmable on the MachXO3L/LF device.

Values: 3.5

Default: 3.5

10.1.4. PULLMODE

The PULLMODE option can be enabled or disabled independently for each I/O. When you select OPENDRAIN=ON, the PULLMODE for the output standard is default to NONE.

Values: UP, DOWN, NONE, KEEPER

Default: DOWN for LV TTL and LVC MOS. All others are NONE.

10.1.5. CLAMP

The CLAMP option can be enabled or disabled independently for each I/O. The settings are available on the bottom edge. All other I/O have ON or OFF settings for this attribute.

Values: OFF, ON

Default value of the CLAMP for output: OFF

Default value of the CLAMP for input: ON if V_{CCIO} is the same or higher than the I/O standard.

Default value of the CLAMP for input: OFF if V_{CCIO} is lower than the I/O standard.

When the CLAMP DIODE is ON, careful design considerations must be followed. See [Appendix D](#) for more information.

10.1.6. HYSTERESIS

The ratioed input buffers have two input hysteresis settings. The HYSTERESIS option can be used to change the amount of hysteresis for the LV TTL and LVC MOS input and bidirectional I/O standards, except for the LVC MOS12 inputs. The LVC MOS12 inputs do not support HYSTERESIS.

The LVC MOS25R33, LVC MOS18R25, LVC MOS18R33, LVC MOS15R25, LVC MOS15R33, LVC MOS12R33, LVC MOS12R25, LVC MOS10R33, and LVC MOS10R25 input types do not support HYSTERESIS. The HYSTERESIS option for each of the input pins can be set independently when it is supported for the I/O type.

Values: SMALL, LARGE, NA

Default: SMALL

10.1.7. VREF

The VREF option is enabled for referenced LVCMOS input buffers. The referenced LVCMOS input buffers are specified by choosing the I/O type as LVCMOS25R33, LVCMOS18R25, LVCMOS18R33, LVCMOS15R25, LVCMOS15R33, LVCMOS12R33, LVCMOS12R25, LVCMOS10R33, or LVCMOS10R25. The default value of NA applies for all I/O types that do not use a VREF signal.

The VREF defaults to external VREF pin for the single-ended LVCMOS25R33, LVCMOS18R25, LVCMOS18R33, LVCMOS15R25, LVCMOS15R33, LVCMOS12R33, LVCMOS12R25, LVCMOS10R33, or LVCMOS10R25 inputs. You may enter a VREF_NAME value in the VREF Locations' pop-up window of the Spreadsheet View of the Lattice Diamond software. By doing so, the software presents the VREF_NAME as an available value in the VREF column of the Port Assignments tab of the Diamond Spreadsheet View. A pin location specified by the VREF_NAME value is used as the VREF driver for that I/O bank.

VREF_NAME is only necessary if you want to specify a pin to be used as an external VREF pin. Otherwise, the software automatically assigns a pin for the VREF signal. There is only one VREF pin per I/O bank and only one VREF driver can be used in each I/O bank. This attribute can be set in the software interface or in the ASCII preference file.

Values: N/A or VREF_NAME

Software Default: NA

Hardware Default (Erased): OFF

10.1.8. OPENDRAIN

The OPENDRAIN option is available for all LVTTTL and LVCMOS output and bidirectional I/O standards. Each sysI/O can be assigned independently to be open drain. When the OPENDRAIN attribute is used, the PULLMODE must be NONE and the CLAMP must be OFF.

Values: OFF, ON

Default: OFF

10.1.9. SLEWRATE

Each I/O pin has an individual slew rate control. This allows you to specify slew rate control on a pin-by-pin basis for outputs and bidirectional I/O pins. This is not a valid attribute for inputs or true differential outputs.

Values: FAST, SLOW, NA

Default: SLOW

10.1.10. DIFFRESISTOR

The bottom side I/O pins support on-chip differential input termination resistors. The termination resistor is available for both the primary pair and the alternate pair of a sysI/O. The values supported are OFF or 100 Ω .

Values: OFF, 100

Default: OFF

10.1.11. DIN/DOUT

The DIN/DOUT option is available for each I/O and can be configured independently. An input register is used for the input if the DIN attribute is assigned. Similarly, the software assigns an output register when the DOUT attribute is specified. By default, the software automatically assigns DIN or DOUT to input or output registers if possible.

10.1.12. LOC

This attribute specifies the site location for the component after the mapping process. When attached to multiple components, it indicates that these blocks are to be mapped together in the specified site. It specifies the PIC site for the pad when it is assigned to a pad. The LOC attribute can be attached to components that ends up on an I/O cell, clocks, and internal flip-flops. However, it should not be attached to combinational logic that end up on a logic cell, as doing so can cause failure in generating a locate preference. The LOC attribute overrides register ordering.

10.1.13. Bank V_{CCIO}

This attribute is necessary to verify the valid I/O types for a bank, to determine which input buffer to use, and to set the correct drive strength for the applicable I/O types. Since the I/O bank information is not required at the HDL level, this attribute is available through either the Lattice Diamond Software Spreadsheet View or in the ASCII preference file.

Values: AUTO, 3.3, 2.5, 1.8, 1.5, 1.2

Default: AUTO

10.2. sysI/O Primitives

There are many sysI/O primitives in the software library. A few are selected to be discussed in this section because some sysI/O capabilities can only be utilized through instantiating the primitives in the HDL source code.

10.2.1. Tri-State All (TSALL)

The MachXO3L/LF device supports the TSALL function that is used to enable or disable the tristate control to all the output buffers. You can choose to assign any general purpose I/O pin to control the TSALL function since there is no dedicated TSALL pin. The TSALL primitive must be instantiated in the source code in order to enable the TSALL function. The input of the primitive can be assigned to an input pin or to an internal signal.

A value of TSALL=1 tristates all outputs but the outputs are under individual OE control when TSALL=0.

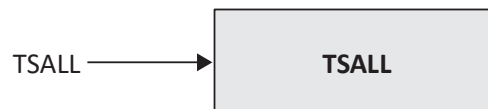

Figure 10.1. TSALL Primitive

10.2.2. Fixed Data Delay (DELAYE)

This primitive supports up to 32 steps of static delay for all sysI/O buffers in all banks of a MachXO3L/LF device. Refer to the External Switching Characteristics table in [MachXO3 Family Data Sheet \(FPGA-DS-02032\)](#) for delay step values. Although you can choose the USER_DEFINED mode to set input delay, this primitive is primarily used by the pre-defined source synchronous interfaces, as described in [Implementing High-Speed Interfaces with MachXO3 Devices \(FPGA-TN-02057\)](#).



Figure 10.2. DELAYE Primitive and Associated Attributes

Table 10.3. DELAYE Primitive and Associated Attributes

Attribute	Description	Value	Software Default
DEL_MODE	Fixed delay value depending on interface or user-defined delay values	SCLK_ZEROHOLD ECLK_ALIGNED ECLK_CENTERED SCLK_ALIGNED SCLK_CENTERED USER_DEFINED	USER_DEFINED
DEL_VALUE	User-defined value	DELAY0...DELAY31	DELAY0

10.2.3. Dynamic Data Delay (DELAYD)

This primitive supports dynamic delay for the sysI/O buffers in the bottom bank, that is, Bank 2 of the MachXO3L/LF device only. The 5-bit inputs can be controlled by user logic to modify the delay during the device operation.

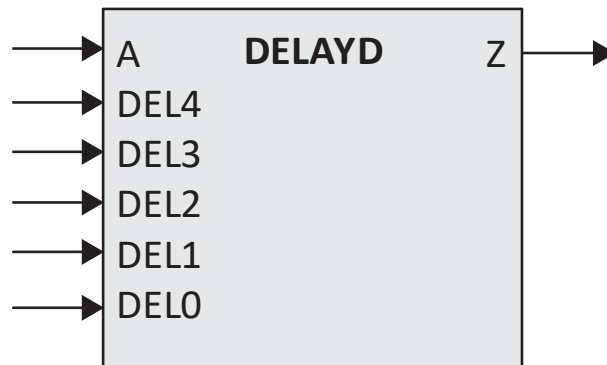

Figure 10.3. DELAYE Primitive

11. Design Consideration and Usage

This section summarizes the MachXO3L/LF designs rules and considerations that have been discussed in detail in previous sections. Table 11.1 lists the miscellaneous I/O features on each side of a MachXO3L/LF device.

11.1. sysI/O Buffer Features Common to All MachXO3L/LF Devices

- All banks support true differential inputs.
- All banks support emulated differential outputs using external resistors and complementary LVCMOS outputs. Emulated differential output buffers are supported on both primary and alternate pairs.
- All banks have programmable I/O clamps.
- All banks support weak pull-up, pull-down, and bus-keeper settings on each I/O independently.
- V_{CCIO} voltage levels, together with the selected I/O types, determine the characteristics of an I/O, such as the pull mode, hysteresis, clamp behavior, and drive strength, supported in a bank. Each bank can support 1.2 V inputs regardless of the V_{CCIO} setting of the bank.
- Each bank supports one V_{CCIO} signal.

11.2. sysI/O Buffer Rules

- Only the top side Bank 0 supports true differential output buffers with programmable drive strengths. Only the primary pair supports true differential output buffers.
- Only the bottom side Bank 2 supports internal 100 Ω differential input terminations.

Table 11.1. Miscellaneous I/O Features on Each Device Edge

Feature	Top	Bottom	Left	Right
100 Ω Differential Resister	—	Yes	—	—
Hot Socket	Yes	Yes	Yes	Yes
Clamp ²	Yes	Yes	Yes	Yes
Weak Pull-up ²	Yes	Yes	Yes	Yes
Weak Pull-down ¹	Yes	Yes	Yes	Yes
Bus Keeper ²	Yes	Yes	Yes	Yes
Input Hysteresis ²	Yes	Yes	Yes	Yes
Slew Rate Control	Yes	Yes	Yes	Yes
Open Drain	Yes	Yes	Yes	Yes

Notes:

1. Software default setting.
2. I/O characteristic under special conditions:
 - a. HYSTERESIS option is not available for LVCMOS12.
 - b. HYSTERESIS option and BUS KEEPER option are not available for referenced input standards.
 - c. When using the ratioed input buffers in under-drive or over-drive conditions, the HYSTERESIS setting shall be NA, the CLAMP setting shall be OFF, and the UP and KEEPER PULLMODE settings are not supported.
 - d. HYSTERESIS and the bus maintenance capabilities are disabled for differential receivers.

Appendix A – sysI/O HDL Attributes

The sysI/O attributes can be used directly in the HDL source codes. This section provides a list of sysI/O attributes supported by the MachXO3L/LF PLD family. The correct syntax and examples for the Synplify® synthesis tool are provided here for reference.

A.1. Attributes in VHDL Language

This section lists syntax and examples for the sysI/O attributes in VHDL.

Syntax

Table A.1. VHDL Attribute Syntax

Attribute	Syntax
IO_TYPE	attribute IO_TYPE: string; attribute IO_TYPE of Pinname: signal is "IO_TYPE Value";
DRIVE	attribute DRIVE: string; attribute DRIVE of Pinname: signal is "Drive Value";
DIFFDRIVE	attribute DIFFDRIVE: string; attribute DIFFDRIVE of Pinname: signal is "Diffdrive Value";
DIFFRESISTOR	attribute DIFFRESISTOR: string; attribute DIFFRESISTOR of Pinname: signal is "Diffresistor Value";
CLAMP	attribute CLAMP: string; attribute CLAMP of Pinname: signal is "Clamp Value";
HYSTERESIS	attribute HYSTERESIS: string; attribute HYSTERESIS of Pinname: signal is "Hysteresis Value";
VREF	NA
PULLMODE	attribute PULLMODE: string; attribute PULLMODE of Pinname: signal is "Pullmode Value";
OPENDRAIN	attribute OPENDRAIN: string; attribute OPENDRAIN of Pinname: signal is "OpenDrain Value";
SLOWSLEW	attribute SLOWSLEW: string; attribute SLOWSLEW of Pinname: signal is "Slewrates Value";
DIN	attribute DIN: string; attribute DIN of Pinname: signal is " ";
DOUT	attribute DOUT: string; attribute DOUT of Pinname: signal is " ";
LOC	attribute LOC: string; attribute LOC of Pinname: signal is "pin_locations";
BANK V _{CCIO}	NA

Examples

IO_TYPE

```
--***Attribute Declaration*** ATTRIBUTE IO_TYPE: string;
--***IO_TYPE assignment for I/O Pin***
ATTRIBUTE IO_TYPE OF portB: SIGNAL IS "LVCMOS33";
ATTRIBUTE IO_TYPE OF portD: SIGNAL IS "LVDS25";
```

DRIVE

```
--***Attribute Declaration***  
ATTRIBUTE DRIVE: string;  
--***DRIVE assignment for I/O Pin***  
ATTRIBUTE DRIVE OF portB: SIGNAL IS "8";
```

DIFFDRIVE

```
--***Attribute Declaration***  
ATTRIBUTE DIFFDRIVE: string;  
--*** DIFFDRIVE assignment for I/O Pin***  
ATTRIBUTE DIFFDRIVE OF portD: SIGNAL IS "2.0";
```

DIFFRESISTOR

```
--***Attribute Declaration***  
ATTRIBUTE DIFFRESISTOR: string;  
--*** DIFFRESISTOR assignment for I/O Pin***  
ATTRIBUTE DIFFRESISTOR OF portD: SIGNAL IS "100";
```

CLAMP

```
--***Attribute Declaration***  
ATTRIBUTE CLAMP: string;  
--*** CLAMP assignment for I/O Pin***  
ATTRIBUTE CLAMP OF portA: SIGNAL IS "PCI33";
```

HYSTERESIS

```
--***Attribute Declaration***  
ATTRIBUTE HYSTERESIS: string;  
--*** HYSTERESIS assignment for Input Pin***  
ATTRIBUTE HYSTERESIS OF portA: SIGNAL IS " LARGE ";
```

PULLMODE

```
--***Attribute Declaration***  
ATTRIBUTE PULLMODE : string;  
--***PULLMODE assignment for I/O Pin***  
ATTRIBUTE PULLMODE OF portA: SIGNAL IS "DOWN";  
ATTRIBUTE PULLMODE OF portB: SIGNAL IS "UP";
```

OPENDRAIN

```
--***Attribute Declaration***  
ATTRIBUTE OPENDRAIN: string;  
--***Open Drain assignment for I/O Pin***  
ATTRIBUTE OPENDRAIN OF portB: SIGNAL IS "ON";
```

SLEWRATE

```
--***Attribute Declaration***  
ATTRIBUTE SLEWRATE : string;  
--*** SLEWRATE assignment for I/O Pin***  
ATTRIBUTE SLEWRATE OF portB: SIGNAL IS "FAST";
```

DIN/DOUT

```
--***Attribute Declaration***
ATTRIBUTE din : string; ATTRIBUTE dout : string;
--*** din/dout assignment for I/O Pin***
ATTRIBUTE din OF input_vector: SIGNAL IS "TRUE ";
ATTRIBUTE dout OF output_vector: SIGNAL IS "TRUE ";
```

LOC

```
--***Attribute Declaration***
ATTRIBUTE LOC : string;
--*** LOC assignment for I/O Pin***
ATTRIBUTE LOC OF input_vector: SIGNAL IS "E3,B3,C3 ";
```

A.2. Attributes in Verilog Language

This section lists syntax and examples for the sysI/O Attributes in Verilog.

Syntax

Table A.2. VHDL Attribute Syntax

Attribute	Syntax
IO_TYPE	PinType PinName /* synthesis IO_Type="IO_Type Value"*/;
DRIVE	PinType PinName /* synthesis DRIVE="Drive Value"*/;
DIFFDRIVE	PinType PinName /* synthesis DIFFDRIVE = " DIFFDRIVE Value"*/;
DIFFRESISTOR	PinType PinName /* synthesis DIFFRESISTOR = " DIFFRESISTOR Value"*/;
CLAMP	PinType PinName /* synthesis CLAMP = " Clamp Value"*/;
HYSTERESIS	PinType PinName /*synthesis HYSTERESIS = "Hysteresis Value" */;
VREF	N/A
PULLMODE	PinType PinName /* synthesis PULLMODE="Pullmode Value"*/;
OPENDRAIN	PinType PinName /* synthesis OPENDRAIN ="OpenDrain Value"*/;
SLEWSLEW	PinType PinName /* synthesis SLEWRATE="Slewrates Value"*/;
DIN	PinType PinName /* synthesis DIN= "value" */;
DOUT	PinType PinName /* synthesis DOUT= "value" */;
LOC	PinType PinName /* synthesis LOC="pin_locations "*/;
Bank V _{CCIO}	N/A

Examples

//IO_TYPE, PULLMODE, SLEWRATE and DRIVE assignment

```
output portB /*synthesis IO_TYPE="LVCMOS33"
PULLMODE ="UP" SLEWRATE ="FAST" DRIVE ="20"*/;
output portC /*synthesis IO_TYPE="LVDS25" */;
```

//DIFFDRIVE

```
output portD /* synthesis IO_TYPE="LVDS25" DIFFDRIVE="2.0"*/;
```

//DIFFRESISTOR

```
output [4:0] portA /* synthesis IO_TYPE="LVDS25" DIFFRESISTOR ="100"*/;
```

//CLAMP

```
output portA /*synthesis IO_TYPE="LVCMOS33" CLAMP ="ON" */;
```

//HYSTERESIS

```
input mypin /* synthesis HYSTERESIS = "LARGE" */;
```

//OPENDRAIN

```
output portA /*synthesis OPENDRAIN ="ON"*/;
```

// DIN Place the flip-flops near the load input

```
input load /* synthesis din="" TRUE */;
```

// DOUT Place the flip-flops near the outload output

```
output outload /* synthesis dout="TRUE" */;
```

//LOC pin location

```
input [3:0] DATA0 /* synthesis loc="E3,B1,F3"*/;
```

//LOC Register pin location

```
reg data_in_ch1_buf_reg3 /* synthesis loc="R10C16" */;
```

//LOC Vectored internal bus

```
reg [3:0] data_in_ch1_reg /*synthesis loc ="R10C16,R10C15,R10C14,R10C9" */;
```

Appendix B – sysI/O HDL Attributes Using Spreadsheet View

The sysI/O buffer attributes can be assigned using the Spreadsheet View available in the Lattice Diamond design tool. The attributes that are not available as HDL attributes, such as Bank V_{CCIO}, are available in the Spreadsheet View user interface.

The Port Assignment tab lists all the ports in a design and all the available sysI/O attributes as preferences. Click on each of these cells for a list of all the valid I/O preferences for that port. Each column takes precedence over the next. Therefore, when a particular IO_TYPE is chosen, the columns for the DRIVE, PULL-MODE, SLEW-RATE, and other attributes list the valid combinations for that IO_TYPE. Pin locations can be locked using the Pin column of the Port Assignment tab. Right-clicking on a cell lists all the available pin locations. The Spreadsheet View can run a design rule check (DRC) to check for incorrect sysI/O attribute assignments.

All the preferences assigned using the Spreadsheet View are written into the .lpf logical preference file.

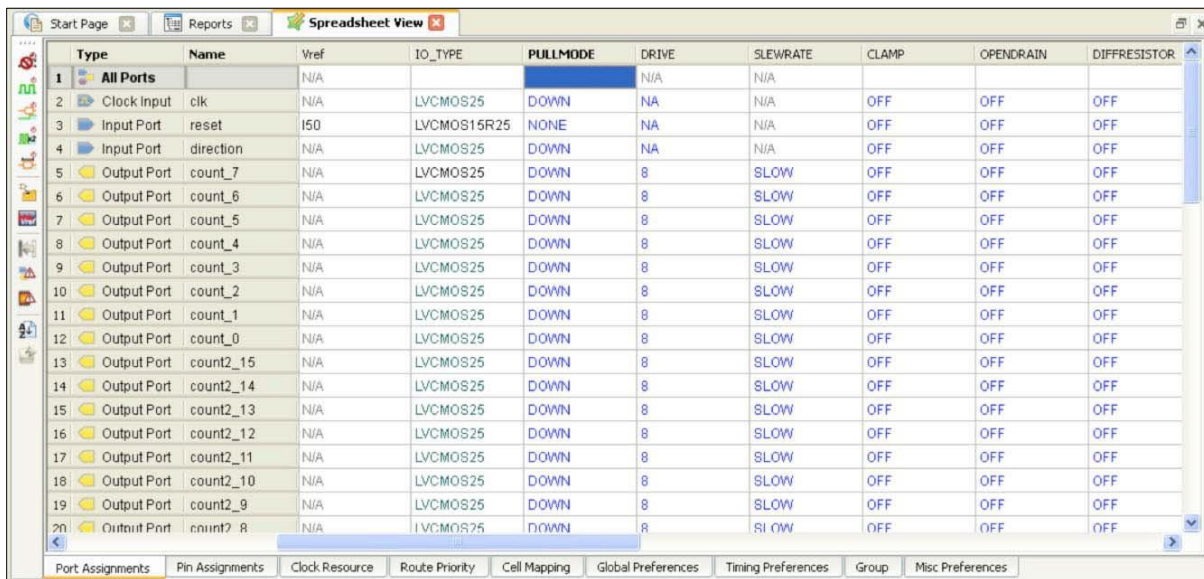

Type	Name	Vref	IO_TYPE	PULLMODE	DRIVE	SLEWRATE	CLAMP	OPENDRAIN	DIFFRESISTOR
1	All Ports	N/A			N/A	N/A			
2	Clock Input clk	N/A	LVCMOS25	DOWN	NA	N/A	OFF	OFF	OFF
3	Input Port reset	I50	LVCMOS15R25	NONE	NA	N/A	OFF	OFF	OFF
4	Input Port direction	N/A	LVCMOS25	DOWN	NA	N/A	OFF	OFF	OFF
5	Output Port count_7	N/A	LVCMOS25	DOWN	8	SLOW	OFF	OFF	OFF
6	Output Port count_6	N/A	LVCMOS25	DOWN	8	SLOW	OFF	OFF	OFF
7	Output Port count_5	N/A	LVCMOS25	DOWN	8	SLOW	OFF	OFF	OFF
8	Output Port count_4	N/A	LVCMOS25	DOWN	8	SLOW	OFF	OFF	OFF
9	Output Port count_3	N/A	LVCMOS25	DOWN	8	SLOW	OFF	OFF	OFF
10	Output Port count_2	N/A	LVCMOS25	DOWN	8	SLOW	OFF	OFF	OFF
11	Output Port count_1	N/A	LVCMOS25	DOWN	8	SLOW	OFF	OFF	OFF
12	Output Port count_0	N/A	LVCMOS25	DOWN	8	SLOW	OFF	OFF	OFF
13	Output Port count2_15	N/A	LVCMOS25	DOWN	8	SLOW	OFF	OFF	OFF
14	Output Port count2_14	N/A	LVCMOS25	DOWN	8	SLOW	OFF	OFF	OFF
15	Output Port count2_13	N/A	LVCMOS25	DOWN	8	SLOW	OFF	OFF	OFF
16	Output Port count2_12	N/A	LVCMOS25	DOWN	8	SLOW	OFF	OFF	OFF
17	Output Port count2_11	N/A	LVCMOS25	DOWN	8	SLOW	OFF	OFF	OFF
18	Output Port count2_10	N/A	LVCMOS25	DOWN	8	SLOW	OFF	OFF	OFF
19	Output Port count2_9	N/A	LVCMOS25	DOWN	8	SLOW	OFF	OFF	OFF
20	Output Port count2_8	N/A	LVCMOS25	DOWN	8	SLOW	OFF	OFF	OFF

Figure B.1. Port Assignment Tab of Spreadsheet View

B.1. Attributes in Verilog Language

Bank V_{CCIO} is editable in the Global Preference tab of the Spreadsheet View. You can choose the value of the Bank V_{CCIO} to determine the value of V_{CCIO} of a specific bank.

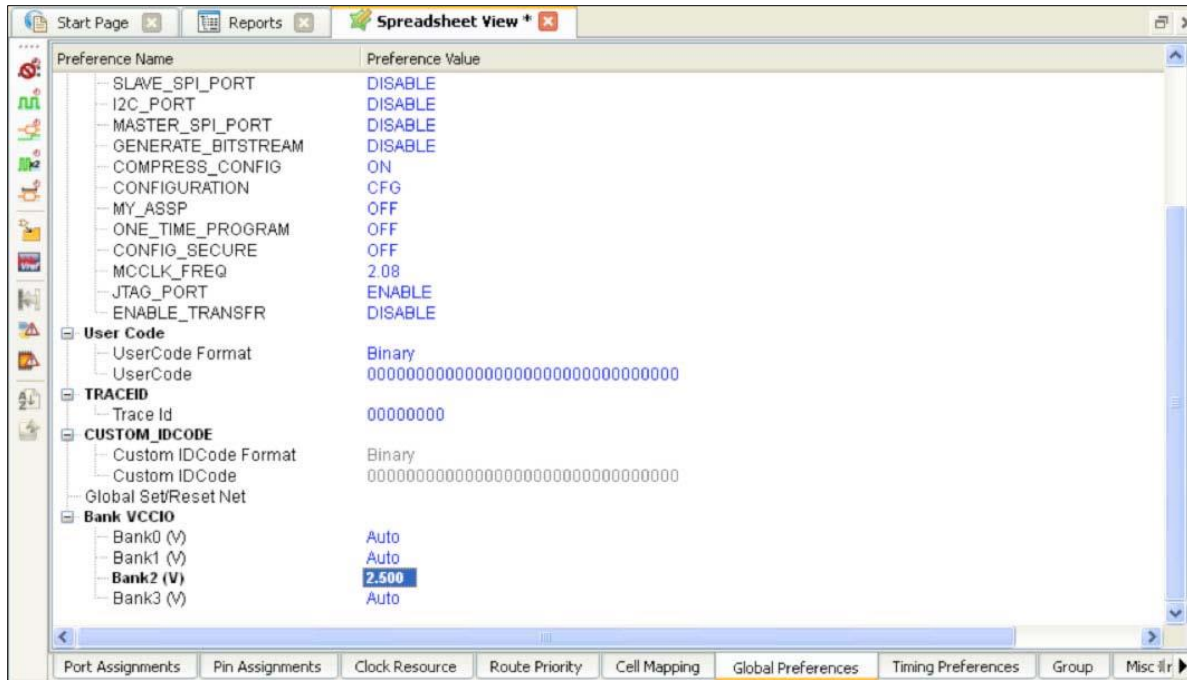

Figure B.2. Cell Attribute Tab

Appendix C – sysI/O Attributes Using Preference File (ASCII File)

You can enter sysI/O attributes directly in the .lpf preference file as sysI/O buffer preferences. The Lattice Preference File (LPF) is a post-synthesis FPGA constraint file that stores logical preferences that have been created or modified in the Spreadsheet View or directly in a text editor. It also contains logical preferences originating in the HDL source. Modifying the Spreadsheet View in the Lattice Diamond software automatically updates the content of the LPF file and it works both ways. The settings in the Spreadsheet View are reflected in the preference file once they are saved. Details of the supported preferences and their corresponding syntax can be found in the Diamond Help system.

Appendix D. Issue: GPIO Input Prevents Powering Down the FPGA

For MachXO3 devices that involve the same voltages for V_{CC} and bank V_{CCIOx} , either 3.3 V or 2.5 V, and they are connected together, careful design consideration must be followed. This is to avoid the FPGA not fully powering down and operating in an undefined state.

Note: Chip failures can occur when the input current limits of the datasheet are exceeded.

D.1. GPIO Input Current Leakage Pathway

The FPGA is powered on, with the bitstream program input CLAMPs on.

While the FPGA powers down, the external circuit continues to drive input pins.

As the FPGA V_{CC} and V_{CCIOx} voltage drop, the GPIO input pins allow external devices to drive reverse current into the FPGA through the on-CLAMPs. This current appears at the V_{CCIOx} pins that are connected to V_{CC} and keep the V_{CC} voltage high enough for the input CLAMPs to remain active.

Other devices besides the FPGA, can be connected to the V_{CC} rail, with each device drawing current from the FPGA. As a result, the FPGA can pass enough reverse current to cause internal burnouts or failures to occur quickly or gradually, depending on the overcurrent of each pin and the number of pins involved.

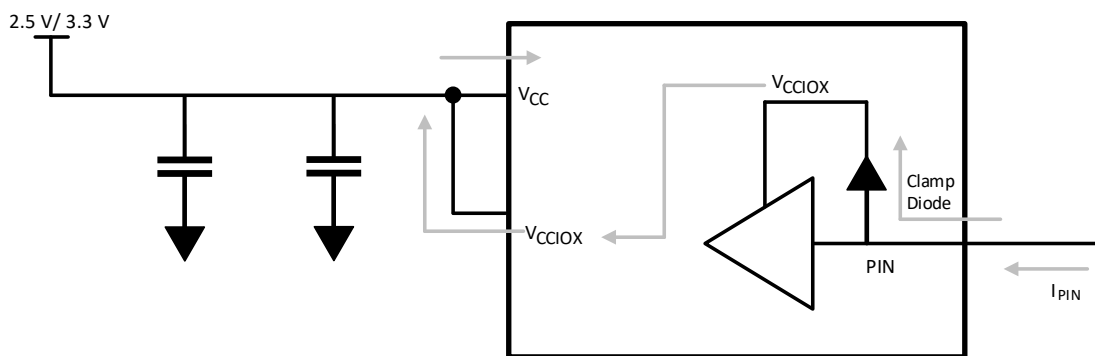

Figure D.1. Potential Current Path for Powered Down FPGA with Driven Input

D.2. Workarounds

Workaround 1

Turn off any external devices connected to the FPGA that are operating at 2.5 V or higher while the FPGA is running.

Workaround 2

Configure the Lattice Diamond software to keep GPIO CLAMPs off in the bitstream when CLAMPs are not required.

Workaround 3

- Ensure that external circuits do not exceed the datasheet I/O pad current limits for banks operating at 2.5 V or higher.
- In each bank, the current should not exceed $n \times 8$ mA. Where n represents the number of I/O pads in between two consecutive power pins. See below scenarios.
 - $V_{CCIO} - I/O_1 - I/O_2 - I/O_x - V_{CCIO}$
 - $GND - I/O_1 - I/O_2 - I/O_x - GND$
 - $V_{CCIO} - I/O_1 - I/O_2 - I/O_x - GND$
- The I/O groupings can be found in the pin tables generated by the Lattice Diamond software.

Example: Limit the pin current by connecting a series resistor to an FPGA GPIO input.

Most non-high-speed designs work well with a 200 Ω to 1 k Ω series resistor.

$$\text{Formula: } R \times C \times 2\text{Tau} = \text{Trise} / \text{Tfall}$$

$$200 \Omega \text{ series resistor at GPIO input} \times 10 \text{ pF etch and pin capacitance} \times 2\text{Tau} = 4\text{ns Trise} / \text{Tfall}$$

Workaround 4

For V_{CCIO} , use a separate voltage regulator with a diode D1 connecting the voltage source to the input.

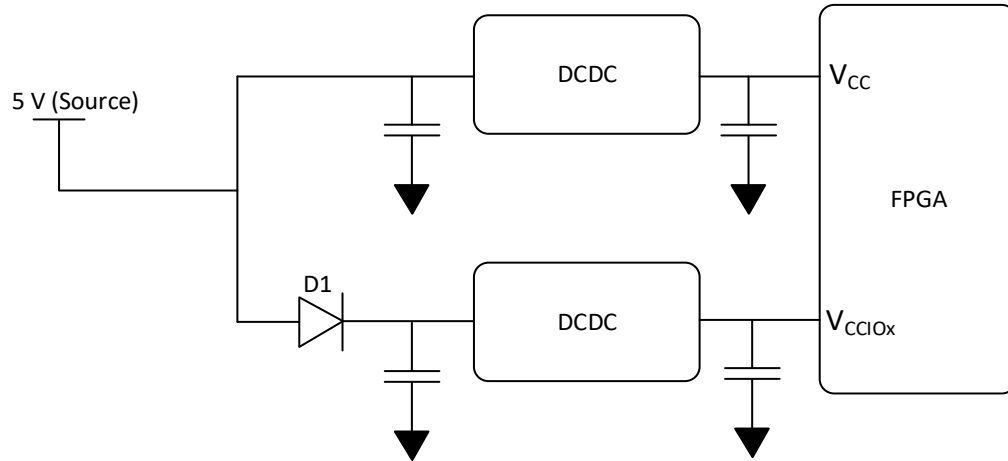

References

For more information refer to:

- [Implementing High-Speed Interfaces with MachXO3 Devices \(FPGA-TN-02057\)](#)
- [MIPI D-PHY Interface IP \(FPGA-RD-02040\)](#)
- [MachXO3 Family Data Sheet \(FPGA-DS-02032\)](#)
- [MachXO3 devices web page](#)
- [Lattice Diamond FPGA design software web page](#)
- [IP and Reference Designs for MachXO3](#)
- [Development Kits and Boards for MachXO3](#)
- [Programming Hardware](#)
- [Lattice Insight](#) for Lattice Semiconductor training courses and learning plans

Technical Support Assistance

Submit a technical support case through www.latticesemi.com/techsupport.

For frequently asked questions, refer to the Lattice Answer Database at www.latticesemi.com/Support/AnswerDatabase.

Revision History

Revision 2.0, June 2025

Section	Change Summary
sysI/O Buffer Overview	<ul style="list-style-type: none"> Changed <i>there are four types of PIC blocks in the MachXO3L/LF device architecture. These include the basic PIC block, the memory PIC block for Double Data Rate (DDR) memory support, the receiving PIC block with gearing, and the transmitting PIC block with gearing to there are three types of PIC blocks in the MachXO3L/LF device architecture. These include the basic PIC block, the receiving PIC block with gearing, and the transmitting PIC block with gearing.</i> Changed <i>a common feature of all four types of PIC blocks is that each PIC block consists of four programmable I/O (PIO) to a common feature of all three types of PIC blocks is that each PIC block consists of four programmable I/O (PIO).</i>
Supported sysI/O Standards	In Table 3.1. Supported Input Standards , changed LVTTL3 to LVTTL33.
Software sysI/O Attributes	<ul style="list-style-type: none"> In the DRIVE section, changed <i>Table 10.2 shows the supported drive strength for the single-ended I/O types under designated VCCIO conditions to Table 10.2 shows the supported drive strength for single-ended I/O types under designated I/O standards.</i> In Table 10.2. Output Drive Capability for Ratioed sysI/O Standards: <ul style="list-style-type: none"> changed V_{CCIO} to <i>Drive Strength (mA)</i> and <i>Differential Inputs to I/O Type</i> in the table header; changed LVCMOS16 to LVCMOS15; changed 16 mA drive strength support of LVCMOS25 from YES to —.

Revision 1.9, January 2025

Section	Change Summary
Disclaimers	Updated the disclaimer.
Abbreviations in This Document	<ul style="list-style-type: none"> Updated the section title to its current. Updated the abbreviations used in this document.
sysI/O Banking Scheme	Added <i>When the CLAMP DIODE is ON, careful design considerations must be followed. See Appendix D for more information.</i>
Software sysI/O Attributes	<ul style="list-style-type: none"> Updated the default value of CLAMP from OFF to <i>Default value of the CLAMP for output: OFF</i> <i>Default value of the CLAMP for input: ON if VCCIO is the same or higher than the I/O standard.</i> <i>Default value of the CLAMP for input: OFF if VCCIO is less than the I/O standard.</i> Added <i>When the CLAMP DIODE is ON, careful design considerations must be followed. See Appendix D for more information.</i>
Issue: GPIO Input Prevents Powering Down the FPGA	Added this appendix.

Revision 1.8, August 2023

Section	Change Summary
Input Reference Voltage	Removed the statement, <i>The input reference voltage can also be generated internally from the VREF generator. Again, there is one VREF generator per bank and VREF value is set to half of VCCIO level. The internal VREF generator and the external VREF pin cannot be set at the same time for a particular bank because there is only one VREF bus per bank.</i>
Software sysI/O Attributes – Section 10.1.7. VREF	<ul style="list-style-type: none"> Replaced LVMCOS with LVCMOS. Removed the statement, <i>There is only one VREF pin or internal VREF driver per I/O bank</i>”, and replaced with <i>“There is only one VREF pin per I/O bank and only one VREF driver can be used in each I/O bank. This attribute can be set in the software interface or in the ASCII preference file.</i>
References	Added this section.

Revision 1.7, March 2020

Section	Change Summary
All	<ul style="list-style-type: none"> Changed document number from TN1280 to FPGA-TN-02056. Updated document template.
Disclaimers	Added this section.
V _{CCIO} Requirement for I/O Standards	Updated table note in Table 7.1.
Input Reference Voltage	Updated content.
Software sysI/O Attributes	Updated content of VREF section.

Revision 1.6, May 2016

Section	Change Summary
Introduction	Removed specific reference to L version.
Supported sysI/O Standards	Corrected typo in LVDS25 value in Table 3.1. Supported Input Standards.
Input Reference Voltage	Added this section.
*Note: This interface can be emulated with external resistors. Refer to MIPI D-PHY Interface IP (FPGA-RD-02040) for information on support for MIPI Input and Output. sysI/O Banking Scheme	Mentioned MachXO3L/LF 9400.
V _{CCIO} Requirement for I/O Standards	<ul style="list-style-type: none"> Fixed grammatical errors. Replaced previous table with new Table 7.1 Mixed Voltage Support for LVCMOS and LVTTTL I/O Types⁸. Corrected reference to Table 7.2 Mixed Voltage Support for Differential Input Standards.
Software sysI/O Attributes	<ul style="list-style-type: none"> Added standards to Table 10.1. Supported I/O Types. Added footnote 3 and 4. Added information to HYSTERESIS section. Added VREF section.
Appendix B. sysI/O Attributes Using the Spreadsheet View	Removed reference to VREF in introductory paragraph.

Revision 1.5, April 2015

Section	Change Summary
Appendix B. sysI/O Attributes Using the Spreadsheet View	<ul style="list-style-type: none"> Removed Figure 8, VREF Name and Location Pop-up Window of the Spreadsheet View. Removed the VREF Assignment in the Spreadsheet View section.

Revision 1.4, April 2015

Section	Change Summary
All	Included MachXO3LF device.
Input Hysteresis	Added information.
Technical Support Assistance	Updated contact information.

Revision 1.3, February 2015

Section	Change Summary
Supported sysI/O Standards	Added MIPI information in: <ul style="list-style-type: none"> Table 3.1. Supported Input Standards (also added footnote) Notes: <ul style="list-style-type: none"> If not specified, refer to mixed voltage support in the Vccio Requirement section. This interface can be emulated with external resistors. Table 3.2. Supported Output Standards
sysI/O Standards Supported by I/O Banks	Added MIPI information in Table 5.2. Differential I/O Standards Supported on Various Sides.
Software sysI/O Attributes	Added MIPI information in Table 10.1. Supported I/O Types.
Vccio Requirement for I/O Standards	<ul style="list-style-type: none"> Updated Table 7.1 Mixed Voltage Support for LVCMOS and LVTTTL I/O Types⁸. Revised information for Inputs and removed footnotes on over drive and under drive conditions. Removed the VCCIO for Same Bank LVCMOS/LVTTTL Input/Output Requirements table.
Emulated Differential Outputs	Added MIPI to examples of output standards.

Revision 1.2, August 2014

Section	Change Summary
Vccio Requirement for I/O Standards	Updated Table 7.1 Mixed Voltage Support for LVCMOS and LVTTTL I/O Types ⁸ . Revised data on Vccio 1.2 V.

Revision 1.1, May 2014

Section	Change Summary
All	Product name/trademark adjustment.
Supported sysI/O Standards	<ul style="list-style-type: none"> Updated Table 3.1. Supported Input Standards. Removed LVTTTL / LVCMOS Differential and added input standards. Updated Notes: <ul style="list-style-type: none"> If not specified, refer to mixed voltage support in the VCCIO Requirement section. This interface can be emulated with external resistors. Table 3.2. Supported Output Standards. Removed LVCMOS Differential output standards.
sysI/O Standards Supported by I/O Banks	Updated Table 5.2. Differential I/O Standards Supported on Various Sides. Removed LVCMOS input and output standards.
Vccio Requirement for I/O Standards	Added Table 7.1 Mixed Voltage Support for LVCMOS and LVTTTL I/O Types ⁸ and Table 7.2 Mixed Voltage Support for Differential Input Standards.

Revision 1.0, February 2014

Section	Change Summary
All	Initial Release.



www.latticesemi.com